

NORTHFIELD

T4002 PLUS+

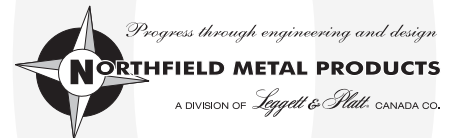

A simple solution for virtually any work place rated and warranted for 350lbs use...



NORTHFIELD T4002 PLUS+

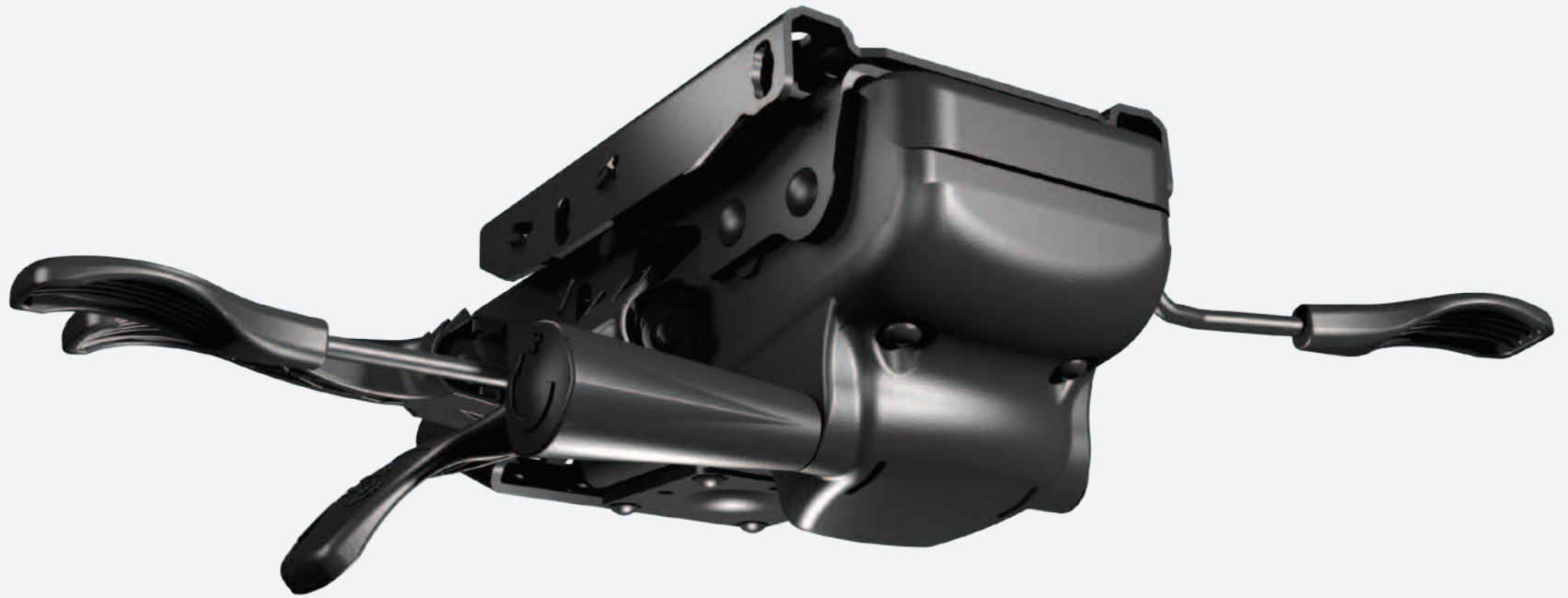

T4002 PLUS+

The T4002-Plus+ Knee-Tilt mechanism is rated and warranted for 350lb use. Providing more spring power than ever before, this mechanism has been re-engineered in order to accommodate larger seating requirements for executive chairs.

This knee tilt promotes keeping your feet on the ground and your thighs parallel to the floor when you recline, thus reducing the pressure on your thighs.

The T4002-Plus+ mechanism has height adjustment (TA), tilt tension (TL), and infinite lock on the several available separate back adjust options.

Complementing the package mechanism package includes options such as Integrated Seat Slider providing 2.5" of travel and Rotary Side Tension.

EXTRAS & OPTIONS

SEPARATE BACK OPTIONS

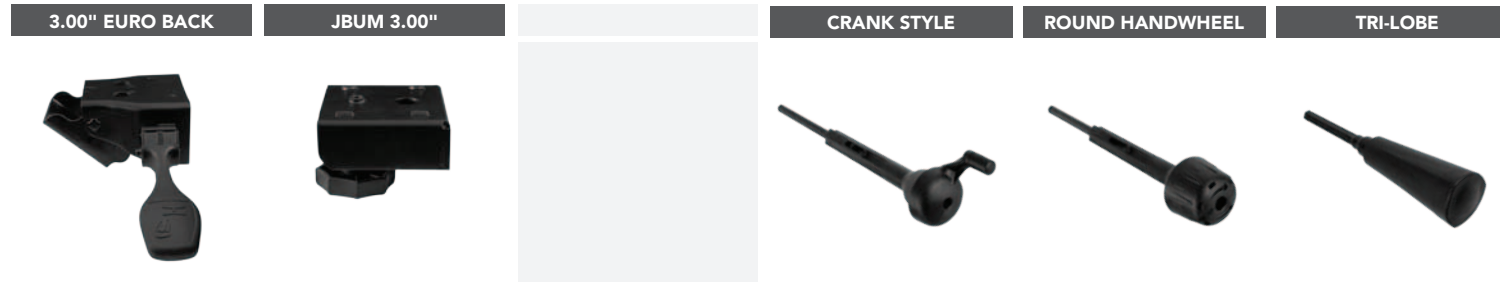

CAM ACTIVATED SEAT SLIDER & 3PC LEVER OPTIONS



HANDWHEEL OPTIONS



SIDE TENSION OPTIONS

SPECIFICATIONS

MECHANISM FEATURES

- TA Top Activation
- TL Infinite Tilt Lock
- HD Heavy Duty Spring

Auto Seat Slider

- Integrated Automotive Style and Cam Activated Seat Sliders (2.50" of travel seat slider factory installed)

FORWARD TILT OPTIONS

- FT Front Tilt Bumper 6° forward

ARM BRACKETS

- ADJ2 Adjustable Arm Brackets
- AT2 Fixed Arm Brackets

GAS CYLINDER TAPERS

- 17-4E Extruded 17-4 Taper

MECHANISM ANGLES

- Seat
 - Forward Tilt 3.5° rearward
 - Rearward Tilt 15°
- Back
 - 16° Travel on Euro back

* 3pc lever paddle options

* Variable locations available by welding in different locations on the seat plate or integrated seat slider
Customer is to specify arm bracket Length and Location for the ADJ2 Welded Arm Bracket.

NORTHFIELD
T4002 PLUS+

CAD

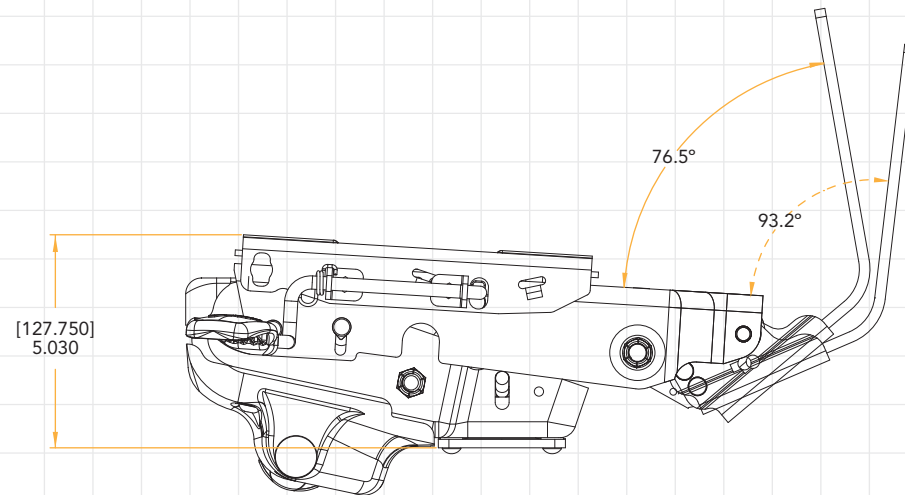
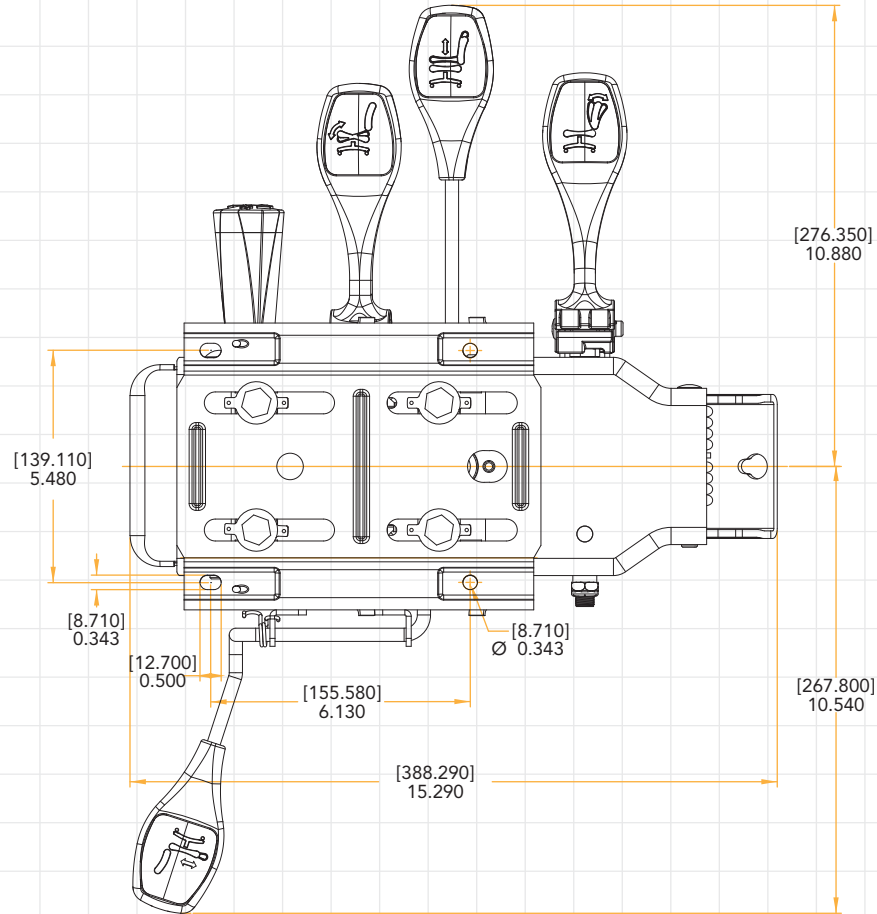

[MILLIMETRES]
INCHES

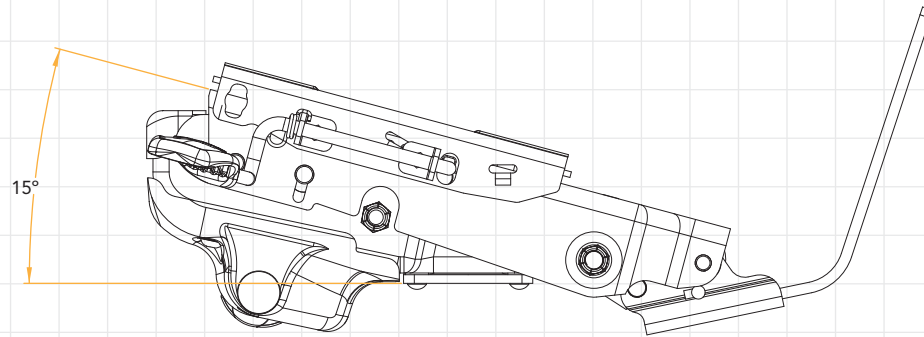
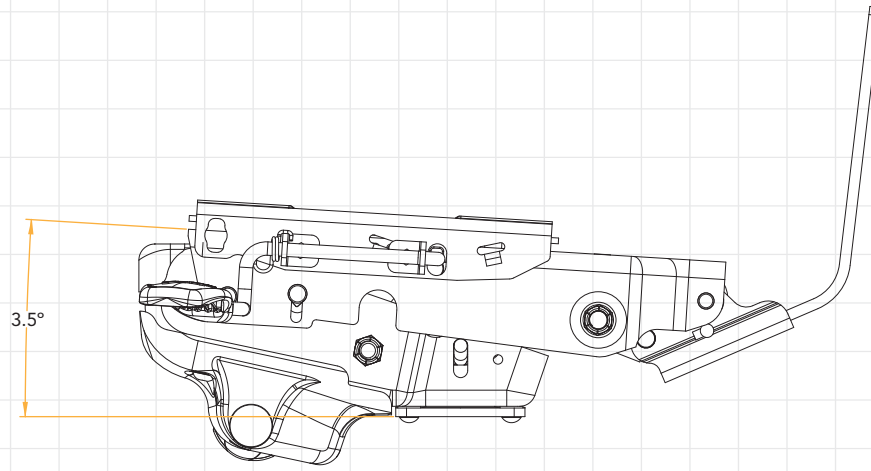

[MILLIMETRES]
INCHES

NORTHFIELD
T4002 PLUS+

CAD

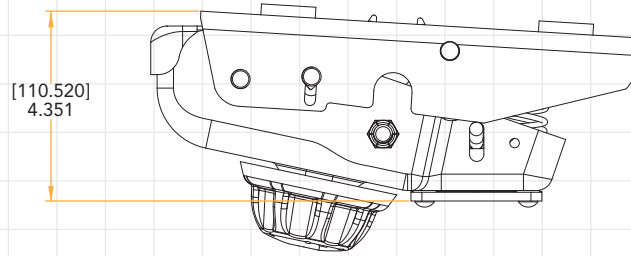
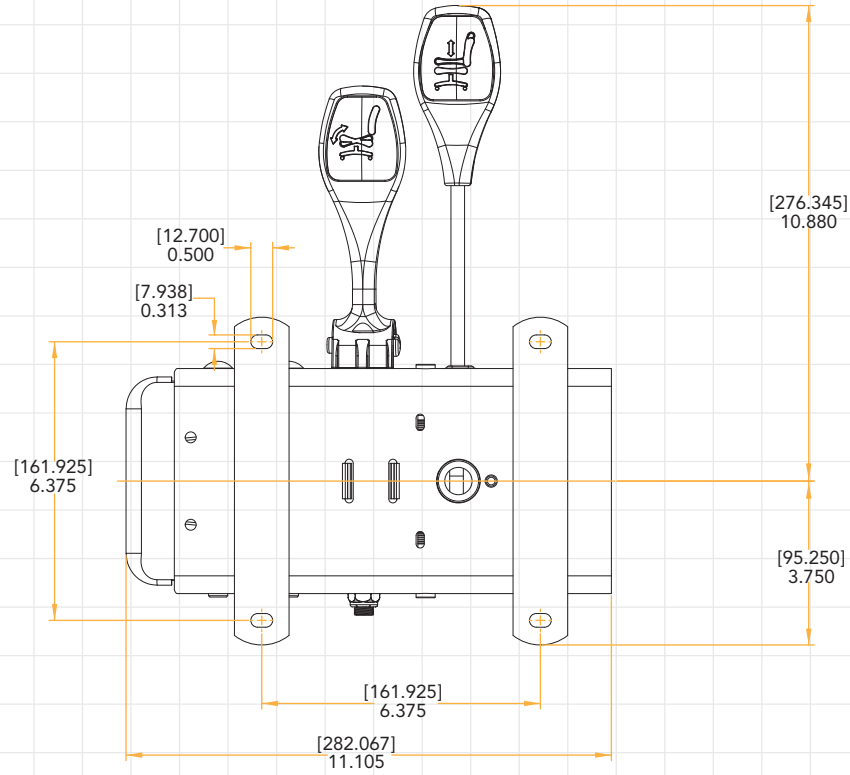

[MILLIMETRES]
INCHES

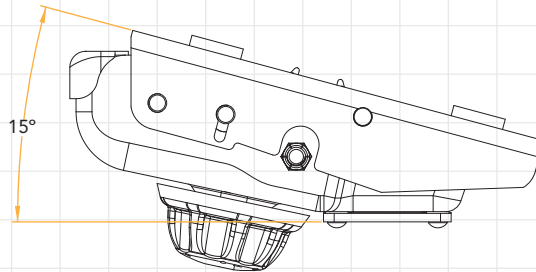
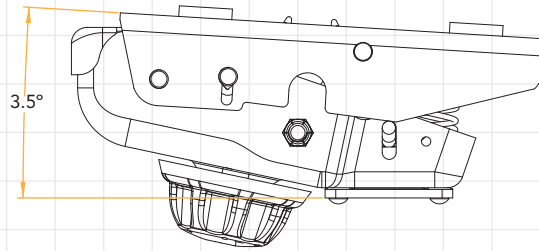

[MILLIMETRES]
INCHES

Northfield Metal Products Ltd.
a division of Leggett & Platt Canada Co.
195 Bathurst Drive
Waterloo, ON N2J 3Z9 CANADA

phone: (519) 884-1860
toll-free: 1 (866) 362-9301 (Canada/USA)
toll-free: 1 (800) 362-9301 (International)
fax: (519) 884-5476
email: sales@northfieldmetal.on.ca

BIFMA
INTERNATIONAL

Manufacturer certifies
that this product meets
or exceeds applicable
ANSI/BIFMA standards.



Progress through engineering and design.

NORTHFIELD METAL PRODUCTS

A DIVISION OF *Leggett & Platt* CANADA CO.

© 2011 Northfield Metal Products Ltd. The shape of a Northfield Chair Control is a TRADE-MARK of Northfield Metal Products. The shape is your guarantee that you have purchased a genuine, high quality product made by Northfield. Northfield Metal Products Ltd. is a division of Leggett & Platt Canada Co. Printed in Canada.